



Model: BTC-9090 Instruction Manual

CONTENTS

- 1. INTRODUCTION
- 2. NUMBERING SYSTEM
- 3. FRONT PANEL DESCRIPTION
- 4. INPUT RANGE & ACCURACY
- 5. SPECIFICATIONS
- 6. INSTALLATION
 - 6.1 DIMENSIONS & PANEL CUTOUT
 - 6.2 WIRING DIAGRAM
- 7. CALIBRATION
- 8. OPERATION
 - 8.1 KEYPAD OPERATION
 - 8.2 FLOW CHART
 - 8.3 PARAMETER DESCRIPTION
 - 8.4 AUTOMATIC TUNING
 - 8.5 MANUAL P.I.D. ADJUSTMENT
 - 8.6 MANUAL TUNING PROCEDURE
 - 8.7 RAMP & DWELL
- 9. ERROR MESSAGES

1. INTRODUCTION

This manual contains information for the installation and operation of the Brainchild model BTC-9090 Fuzzy Logic micro-processor based controller.

The Fuzzy Logic is an essential feature of this versatile controller. Although PID control has been widely accepted by industries, yet it is difficult for PID control to work with some sophistic systems efficiently, for examples systems of second order, long time-lag, various set points, various loads, etc. Because of disadvantage of controlling principles and fixed values of PID control, it is inefficient to control the systems with plenty of varieties, and the result is obviously frustrating for some systems. The Fuzzy Logic control can overcome the disadvantage of PID control, it controls the system in a efficient way by experiences it had before. The function of Fuzzy Logic is to adjust the PID values indirectly in order to making the manipulation output value MV adjusts flexibly and quickly adapt to various processes. By this way, it enables a process to reach its predetermined set point in the shortest time with minimum overshooting during tuning or external disturbance. Different from PID control with digital information, the Fuzzy Logic is a control with language information.

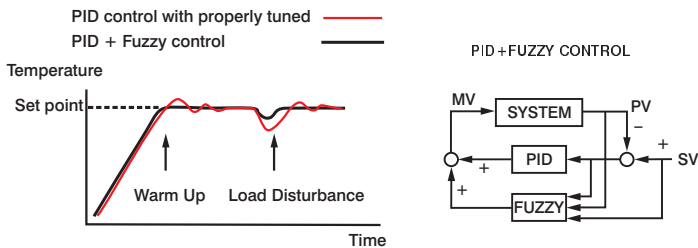

In addition, this instrument has functions of single stage ramp and dwell, auto-tuning and manual mode execution. Ease of use also an essential feature with it.

2. NUMBERING SYSTEM

Model No. —
(1) (2) (3) (4) (5) (6) (7) (8)

(1) Power Input

4	90-264VAC
5	20-32VAC/VDC
9	Other

(2) Signal Input

1	0 - 5V	3	PT100 DIN	5	TC	7	0 - 20mA
8	0 - 10V						

(3) Range Code

1	Configurable
9	Other

(4) Control Mode

3	PID / ON-OFF Control
---	----------------------

(5) Output 1 Option

0	None
1	Relay rated 3A/240VAC resistive
2	SSR Drive rated 20mA/24V
3	4-20mA linear, max. load 500 ohms (Module OM93-1)
4	0-20mA linear, max. load 500 ohms (Module OM93-2)
5	0-10V linear, min. impedance 500K ohms (Module OM93-3)
9	Other

(6) Output 2 Option

0	None
---	------

(7) Alarm Option

0	None
1	Relay rated 2A/240VAC resistive
9	Other

(8) Communication

0	None
---	------

3. FRONT PANEL DESCRIPTION

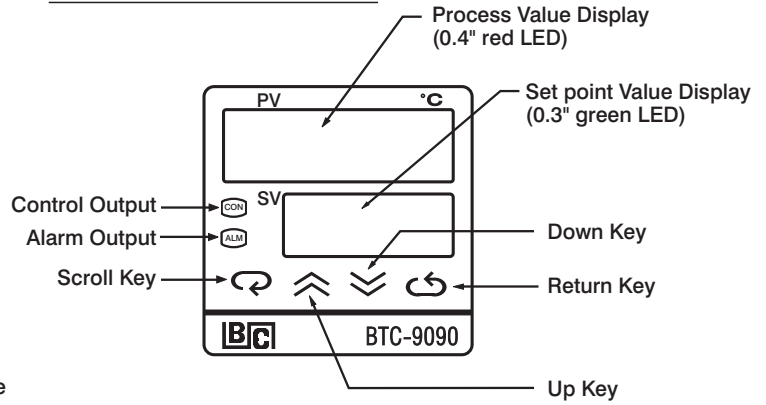

4. INPUT RANGE & ACCURACY

IN	Sensor	Input Type	Range(°C)	Accuracy
0	J	Iron-Constantan	-50 to 999 °C	± 2 °C
1	K	Chromel-Alumel	-50 to 1370 °C	± 2 °C
2	T	Copper-Constantan	-270 to 400 °C	± 2 °C
3	E	Chromel-Constantan	-50 to 750 °C	± 2 °C
4	B	Pt30%RH/Pt6%RH	300 to 1800 °C	± 3 °C
5	R	Pt13%RH/Pt	0 to 1750 °C	± 2 °C
6	S	Pt10%RH/Pt	0 to 1750 °C	± 2 °C
7	N	Nicrosil-Nisil	-50 to 1300 °C	± 2 °C
8	RTD	PT100 ohms(DIN)	-200 to 400 °C	± 0.4 °C
9	RTD	PT100 ohms(JIS)	-200 to 400 °C	± 0.4 °C
10	Linear	-10mV to 60mV	-1999 to 9999	± 0.05%

5. SPECIFICATIONS

INPUT

Thermocouple (T/C):	type J, K, T, E, B, R, S, N.
RTD:	PT100 ohm RTD (DIN 43760/BS1904 or JIS)
Linear:	-10 to 60 mV, configurable input attenuation
Range:	User configurable, refer to Table above
Accuracy:	Refer to Table above
Cold Junction Compensation:	0.1 °C/ °C ambient typical
Sensor Break Protection:	Protection mode configurable
External Resistance:	100 ohms max.
Normal Mode Rejection:	60 dB
Common Mode Rejection:	120dB
Sample Rate:	3 times / second

CONTROL

Proportion Band:	0 - 200 °C (0-360°F)
Reset (Integral):	0 - 3600 seconds
Rate (Derivative):	0 - 1000 seconds
Ramp Rate:	0 - 200.0 °C /minute (0 - 360.0 °F /minute)
Dwell:	0 - 3600 minutes
ON-OFF:	With adjustable hysteresis (0-20% of SPAN)
Cycle Time:	0-120 seconds
Control Action:	Direct (for cooling) and reverse (for heating)

POWER

Rating:	90-264VAC, 50/ 60Hz
Consumption:	Less than 5VA

ENVIRONMENTAL & PHYSICAL

Safety:	UL873, CSA22.2/142-87, IEC1010-1 (EN61010-1)
EMC Emission:	EN50081-1
EMC Immunity:	EN50082-2
Operating Temperature:	-10 to 50 °C
Humidity:	0 to 90 % RH (non-condensing)
Insulation:	20M ohms min. (500 VDC)
Breakdown:	AC 2000V, 50/60 Hz, 1 minute
Vibration:	10 - 55 Hz, amplitude 1 mm
Shock:	200 m/ s ² (20g)
Net Weight:	170 grams
Housing Materials:	Poly-Carbonate Plastic

6. INSTALLATION

6.1 DIMENSIONS & PANEL CUTOUT

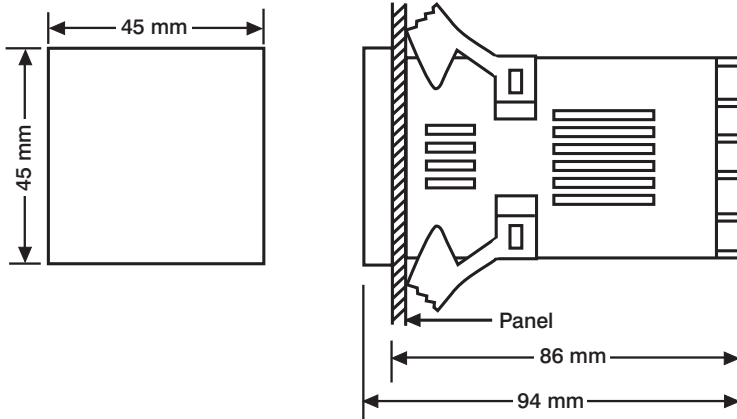
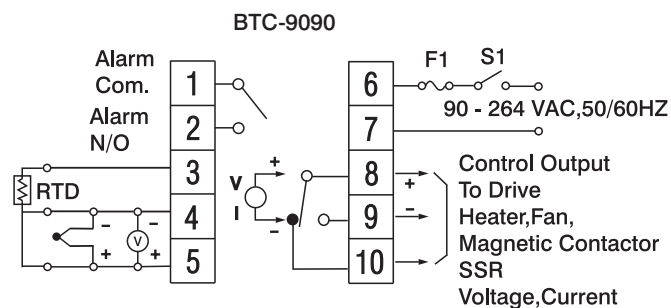

Figure 6.1 Mounting Dimensions

6.2 WIRING DIAGRAM



* F1: Fuse, S1: Power Switch

7. CALIBRATION

Note: Do not proceed through this section unless there is a genuine need to re-calibrate the controller. All previous calibration data will be lost. Do not attempt re-calibration unless you have available appropriate calibration equipment. If calibration data is lost, you will need to return the controller to your supplier who may apply a charge for re-calibration.

Prior to calibration ensure that all parameter settings are correct (input type, °C / °F, resolution, low range, high range).

1. Remove sensor input wiring and connect a standard input simulator of the correct type to the controller input. Verify correct polarity. Set simulated signal to coincide with low process signal (e.g. zero degrees).
2. Use the Scroll Key until the "L CAL" appears on the PV Display. (Refer to 8.2)
3. Use the Up and Down Keys until the SV Display represents the simulated input.
4. Press the Return Key for at least 6 seconds (maximum 16 seconds), then release. This enters the low calibration figure into the controller's non-volatile memory.
5. Press and release the Scroll Key, "H CAL" appears on the PV Display. This indicates the high calibration point.
6. Increase the simulated input signal to coincide with high process signal (e.g. 100 degrees).
7. Use the Up and Down Keys until the SV Display represents the simulated high input.
8. Press the Return Key for at least 6 seconds (maximum 16 seconds), then release. This enters the high calibration figure into the controller's non-volatile memory.
9. Turn power off the unit, remove all test wiring and replace sensor wiring (observing polarity).

8. OPERATION

8.1 KEYPAD OPERATION

* With power on, it has to wait for 12 seconds to memorize the new values of parameters once it been changed.

TOUCHKEYS	FUNCTION	DESCRIPTION
	Scroll Key	Advance the index display to the desired position. Index advanced continuously and cyclically by pressing this keypad.
	Up Key	Increases the parameter
	Down Key	Decreases the parameter
	Return Key	Resets the controller to its normal status. Also stops auto-tuning, output percentage monitoring and manual mode operation.
Press for 6 seconds	Long Scroll	Allows more parameters to be inspected or changed.
Press for 6 seconds	Long Return	1. Executes auto-tuning function 2. Calibrates control when in calibration level
Press and	Output Percentage Monitor	Allows the set point display to indicate the control output value.
Press and for 6 seconds	Manual Mode Execution	Allows the controller to enter the manual mode.

8.2 FLOW CHART

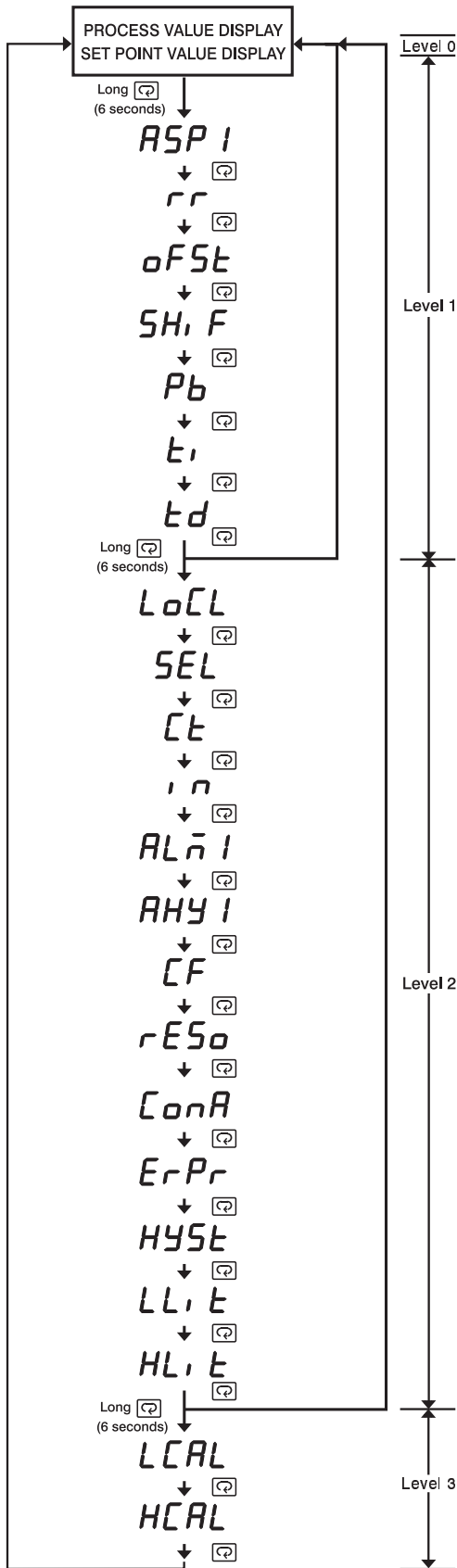

The "return" key can be pressed at any time. This will prompt the display to return to the Process value/Set point value.

Power Applied:

1. 9090 436 Displayed for 4 seconds. (Software Version 3.6 or higher)
2. 8888. 8888. LED test. All LED segments must be lit for 4 seconds.
3. Process value and set point indicated.

8.3 PARAMETER DESCRIPTION

INDEX CODE	DESCRIPTION ADJUSTMENT RANGE	**DEFAULT SETTING
SV	Set point Value Control *Low Limit to High Limit Value	Undefined
ASP1	Alarm Set point Value * Low Limit to High Limit Value.(if $ALn1 = 0, 1, 4$ or 5) * 0 to 3600 minutes (if $ALn1 = 12$ or 13) * Low Limit minus set point to high Limit minus set point value (if $ALn1 = 2, 3, 6$ to 11)	200 °C
rr	Ramp Rate for the process value to limit an abrupt change of process (Soft Start) * 0 to 200.0 °C (360.0 °F) / minute (if $r = 0$ to 9) * 0 to 3600 unit / minute (if $r = 10$)	0 °C / min.
oFSt	Offset Value for Manual Reset (if $t_i = 0$) * 0 to 100%	0.0 %
SH, F	Offset shift for process value * -111 °C to 111 °C	0 °C
Pb	Proportional Band * 0 to 200 °C (set to 0 for on-off control)	10 °C
ti	Integral (Reset) Time * 0 to 3600 seconds	120 sec.
td	Derivative (Rate) Time * 0 to 360.0 seconds	30 sec.
LoCL	Local Mode 0: No control parameters can be changed 1: Control parameters can be changed	1
SEL	Parameter Selection (allows selection of additional parameters to be accessible at level 0 security) 0: None 1: ASP1 2: rr 3: oFSt 4: ASP1, rr 5: ASP1 oFSt 6: rr, oFSt 7: ASP1, rr, oFSt	0
Ct	Proportional Cycle Time * 0 to 120 seconds	Relay 20 Pulsed Voltage 1 Linear Volt/mA 0
in	Input Mode Selection 0: J type T/C 1: K type T/C 2: T type T/C 3: E type T/C 4: B type T/C 5: R type T/C 6: S type T/C 7: N type T/C 8: PT100 DIN 9: PT100 JIS 10: Linear Voltage or Current Note: T/C-Close solder gap G5, RTD-Open G5	T/C 0 RTD 8 Linear 10
ALn1	Alarm Mode Selection 0: Process High Alarm 1: Process Low Alarm 2: Deviation High Alarm 3: Deviation Low Alarm 4: Inhibit Process High Alarm 5: Inhibit Process Low Alarm 6: Inhibit Deviation High Alarm 7: Inhibit Deviation Low Alarm 8: Outband Alarm 9: inband Alarm 10: Inhibit Outband Alarm 11: Inhibit Inband Alarm 12: Alarm Relay OFF as Dwell Time Out 13: Alarm Relay ON as Dwell Time Out	0
AHY1	Hysteresis of Alarm 1 * 0 to 20% of SPAN	0.5%
CF	°C / °F Selection 0: °F, 1: °C	1
rESo	Resolution Selection 0: No Decimal Point 1: 1 Digit Decimal 2: 2 Digit Decimal 3: 3 Digit Decimal (2 & 3 may only be used for linear voltage or current $r = 10$)	0
ConA	Control Action 0: Direct (Cooling) Action 1: Reverse (Heat) Action	1
ErPr	Error Protection 0: Control OFF, Alarm OFF 1: Control OFF, Alarm ON 2: Control ON, Alarm OFF 3: Control ON, Alarm ON	1
HYS	Hysteresis for ON/OFF Control *0 to 20 % of SPAN	0.5%
LL, t	Low Limit of Range	-50 °C
HL, t	High Limit of Range	1000 °C
LCAL	Low Calibration Figure	0 °C
HCAL	High Calibration Figure	800 °C

NOTES: * Adjusting Range of the Parameter
** Factory settings. Process alarms are at fixed temperature points. Deviation alarms move with the set points value.

8.4 AUTOMATIC TUNING

1. Ensure that controller is correctly configured and installed.
2. Ensure Proportional Band 'Pb' is not set at '0'.
3. Press Return Key for at least 6 seconds (maximum 16 seconds). This initialises the Auto-tune function. (To abort auto-tuning procedure press Return Key and release).
4. The Decimal point in lower right hand corner of PV display flashes to indicate Auto-tune is in progress. Auto-tune is complete when the flashing stops.
5. Depending on the particular process, automatic tuning may take up to two hours. Processes with long time lags will take the longest to tune. Remember, while the display point flashes the controller is auto-tuning.

NOTE: If an AT error($AtEr$) occurs, the automatic tuning process is aborted due to the system operating in ON-OFF control(PB=0). The process will also be aborted if the set point is set too close to the process temperature or if there is insufficient capacity in the system to reach set point (e.g. inadequate heating power available). Upon completion of Auto-tune the new P.I.D. settings are automatically entered into the controller's non-volatile memory.

8.5 MANUAL P.I.D. ADJUSTMENT

Whilst the auto-tuning function selects control settings which should prove satisfactory for the majority of processes, you may find it necessary to make adjustments to these arbitrary settings from time to time. This may be the case if some changes are made to the process or if you wish to 'fine-tune' the control settings.

It is important that prior to making changes to the control settings that you record the current settings for future reference. Make slight changes to only one setting at a time and observe the results on the process. Because each of the settings interact with each other, it is easy to become confused with the results if you are not familiar with process control procedures.

TUNING GUIDE

Proportional Band

Symptom	Solution
Slow Response	Decrease PB Value
High Overshoot or Oscillations	Increase PB Value

Integral Time (Reset)

Symptom	Solution
Slow Response	Decrease Integral Time
Instability or Oscillations	Increase Integral Time

Derivative Time (Rate)

Symptom	Solution
Slow Response or Oscillations	Decrease Deriv. Time
High Overshoot	Increase Deriv. Time

8.6 MANUAL TUNING PROCEDURE

- Step 1: Adjust the integral and derivative values to 0. This inhibits the rate and reset action
- Step 2: Set an arbitrary value of proportional band and monitor the control results
- Step 3: If the original setting introduces a large process oscillation, then gradually increase the proportional band until steady cycling occurs. Record this proportional band value(Pc).
- Step 4: Measure the period of steady cycling

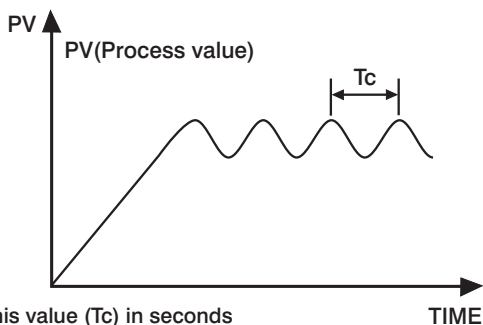

Record this value (T_c) in seconds

Step 5: The Control Settings are determined as follows:

Proportion Band(PB)=1.7 Pc
 Integral Time (TI)=0.5 Tc
 Derivative Time(TD)=0.125 Tc

8.7 RAMP & DWELL

The BTC-9090 controller can be configured to act as either a fixed set point controller or as a single ramp controller on power up. This function enables the user to set a pre-determined ramp rate to allow the process to gradually reach set point temperature, thus producing a 'Soft Start' function.

A dwell timer is incorporated within the BTC-9090 and the alarm relay can be configured to provide either a dwell function to be used in conjunction with the ramp function.

The ramp rate is determined by the ' r_r ' parameter which can be adjusted in the range 0 to 200.0 °C/minute. The ramp rate function is disabled when the ' r_r ' parameter is set to '0'.

The soak function is enabled by configuring the alarm output to act as a dwell timer. The parameter $ALN1$ needs to be set to the value 12. The alarm contact will now operate as a timer contact, with the contact being closed at power up and opening after the elapsed time set at parameter $ASP1$.

If the controller power supply or output is wired through the alarm contact, the controller will operate as a guaranteed soak controller.

In the example below the Ramp Rate is set to 5 °C/minute, $ALN1=12$ and $ASP1=15$ (minutes). Power is applied at zero time and the process climbs at 5 °C/minute to the set point of 125 °C. Upon reaching set point, the dwell timer is activated and after the soak time of 15 minutes, the alarm contact will open, switching off the output. The process temperature will eventually fall at an undetermined rate.

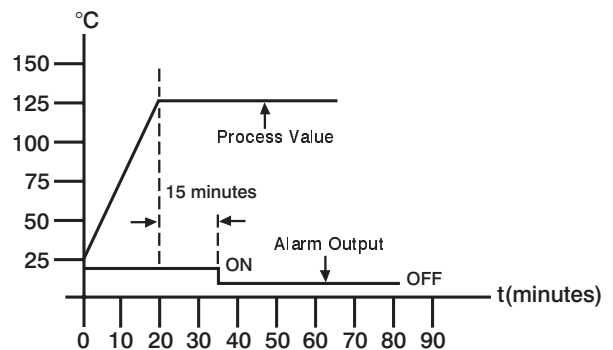

The dwell function may be used to operate an external device such as a siren to alert when a soak time has been reached.

$ALN1$ need to be set to the value 13. The alarm contact will now operate as a timer contact, with the contact being open on the initial start up. The timer begins to count down once the set point temperature is reached. After the setting at $ASP1$ has elapsed, the alarm contact closes.

9. ERROR MESSAGES

Symptom	Cause (s)	Solution (s)
$SbEr$	Sensor break error	Replace RTD or sensor Use manual mode operation
$LLEr$	Process display beyond the low range set point	Re-adjust LL, t value
$HLEr$	Process display beyond the high range set point	Re-adjust HL, t value
$AHEr$	Analog hybrid module damage	Replace module. Check for outside source of damage such as transient voltage spikes
$AtEr$	Incorrect operation of auto tune procedure Prop. Band set to 0	Repeat procedure. Increase Prop. Band to a number larger than 0
$oPEr$	Manual mode is not allowable for an ON-OFF control system	Increase proportional band
$CSEr$	Check sum error, values in memory may have changed accidentally	Check and reconfigure the control parameters

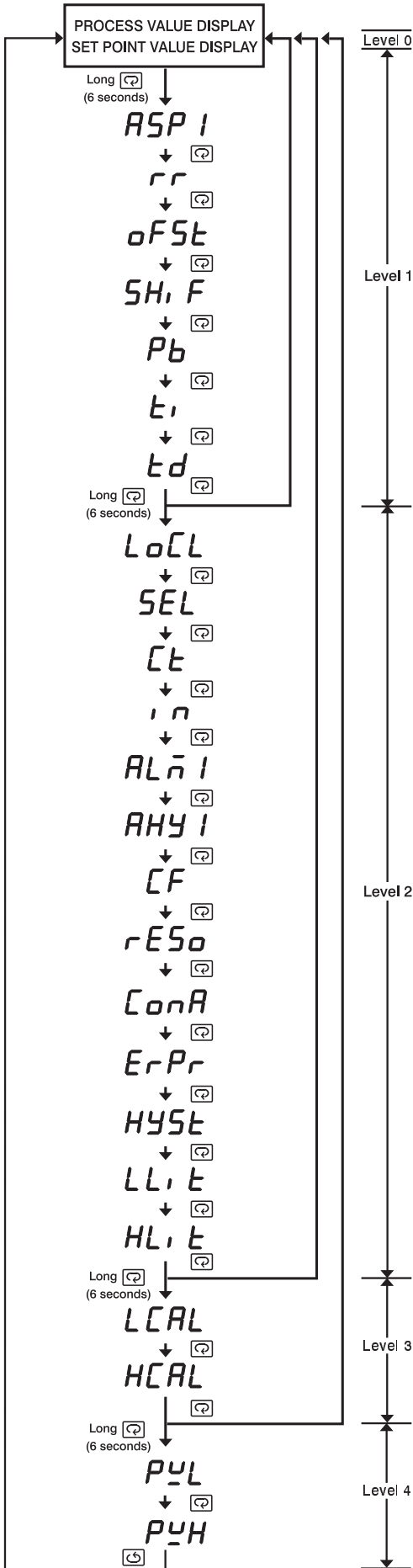

Supplemental Instruction for the New Version

The unit with firmware version V3.7 has two additional parameters - "PVL" and "PVH" located in the level 4 as parameters flow chart on the left hand side.

When you need to change the LLit value to a higher value or change the HLit value to a lower value, following procedures have to be followed to make the PVL value equivalent to one tenth of LCAL value and the PVH value equivalent to one tenth of HCAL value. Otherwise the measured process values will be out of specification.

1. Use the Scroll Key until the "LLit" appears on the PV Display. Use Up and Down Keys to set the LLit value to a higher value than the original value.
2. Press and release the Scroll Key, then "HLit" appears on the PV Display. Use Up and Down Keys to set the HLit value to a lower value than the original value.
3. Turn the power OFF and ON.
4. Use the Scroll Key until the "LCAL" appears on the PV Display. Take a note on the LCAL value.
5. Press and release the Scroll Key, then "HCAL" appears on the PV Display. Take a note on the HCAL value.
6. Press the Scroll Key for at least 6 seconds and then release, "PVL" appears on the PV Display. Use UP and Down Keys to set the PVL value to one tenth of LCAL value.
7. Press and release the Scroll Key, "PVH" appears on the PV Display. Use UP and Down Keys to set the PVH value to one tenth of HCAL value.